

INSTALLATION:

Use threaded holes in the back of electromagnet to mount to mount.

Apply 24 Volts DC to leads. Polarity is unimportant as electromagnets work equally well in forward or reverse polarity.

MAINTENANCE INSTRUCTIONS:

Electromagnets require very little maintenance to provide a long useful life. Daily use of a shop towel to wipe the face of the magnet free of debris, grease and oil or other foreign matter will ensure years of service life and thousands of safe lifts.

MODEL: CEA-600E-24C
INPUT VOLTAGE: 24VDC
POWER: 44 WATTS
HOLDING POWER: 2200 LBS
DUTY CYCLE: CONTINUOUS

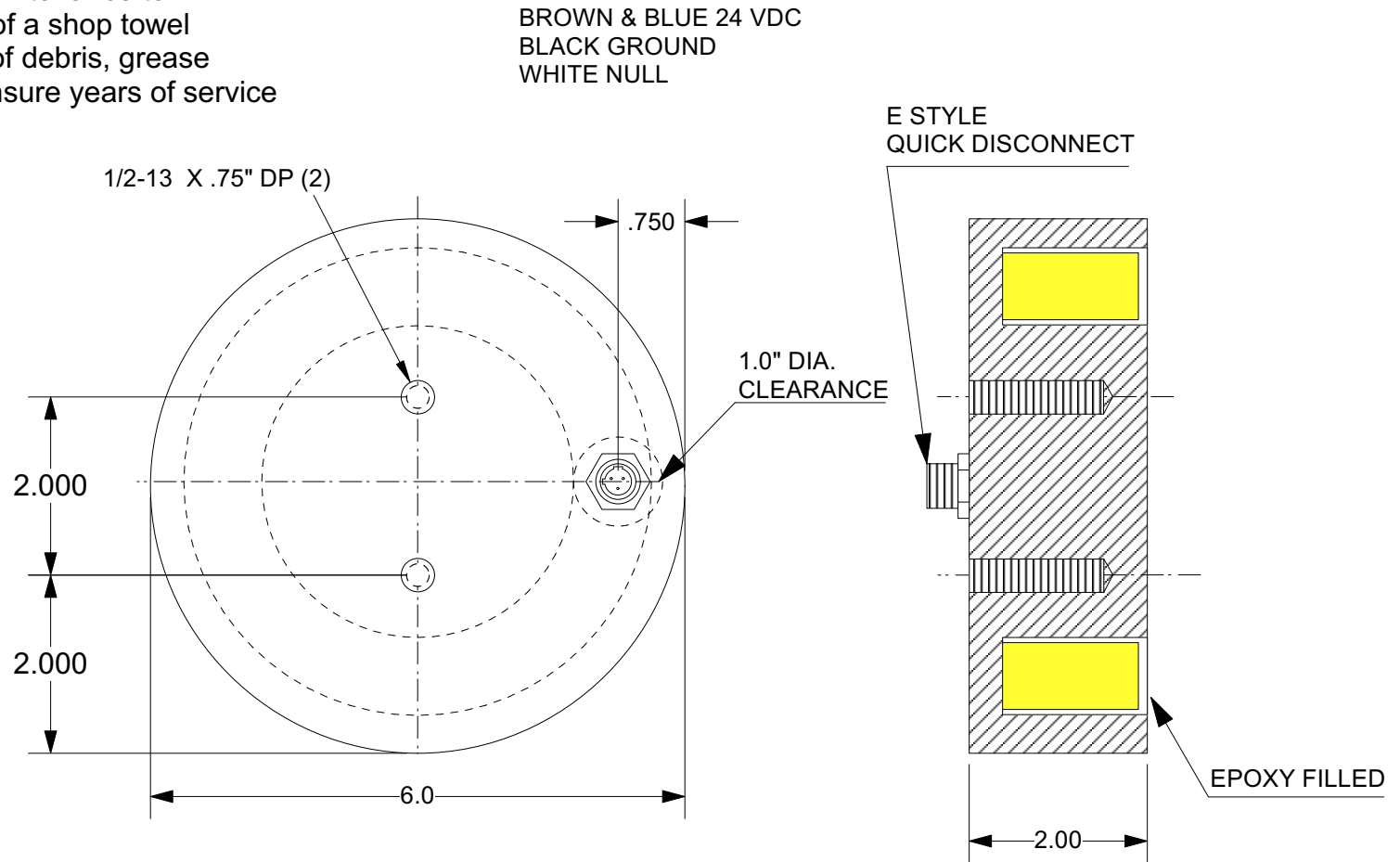

IF YOU HAVE ANY QUESTIONS ABOUT THIS MAGNET OR THE CORRESPONDING DC POWER SUPPLY, PLEASE CALL OUR ENGINEERING DEPARTMENT FOR ASSISTANCE: (1-800-635-3954)

AUTOMATIC EQUIPMENT CORP
CEA-600E-24C
CUST DWG
01/05/22
H-15430