



MAGNETICS

AUTOMATIC EQUIPMENT CORPORATION
4699 INTERSTATE DR. CINCINNATI, OHIO 45246
PHONE: (800) 635-3954 FAX: (800) 635-3955

E-MAIL: aec@aecmagnetics.com ON-LINE: www.aecmagnetics.com

MAGNETIC SPECIALISTS FOR AUTOMATED MANUFACTURING

INSTALLATION:

Use threaded holes in the back of electromagnet to mount.

Apply 24 Volts DC to leads. Polarity is unimportant as electromagnets work equally well in forward or reverse polarity.

MAINTENANCE INSTRUCTIONS:

Electromagnets require very little maintenance to provide a long useful life. Daily use of a shop towel to wipe the face of the magnet free of debris, grease and oil or other foreign matter will ensure years of service life and thousands of safe lifts.

MODEL# DC-125T-24C
VOLTAGE: 24V
CURRENT: 8.2 WATTS
DUTY CYCLE: CONTINUOUS
HOLDING POWER: 70 LBS

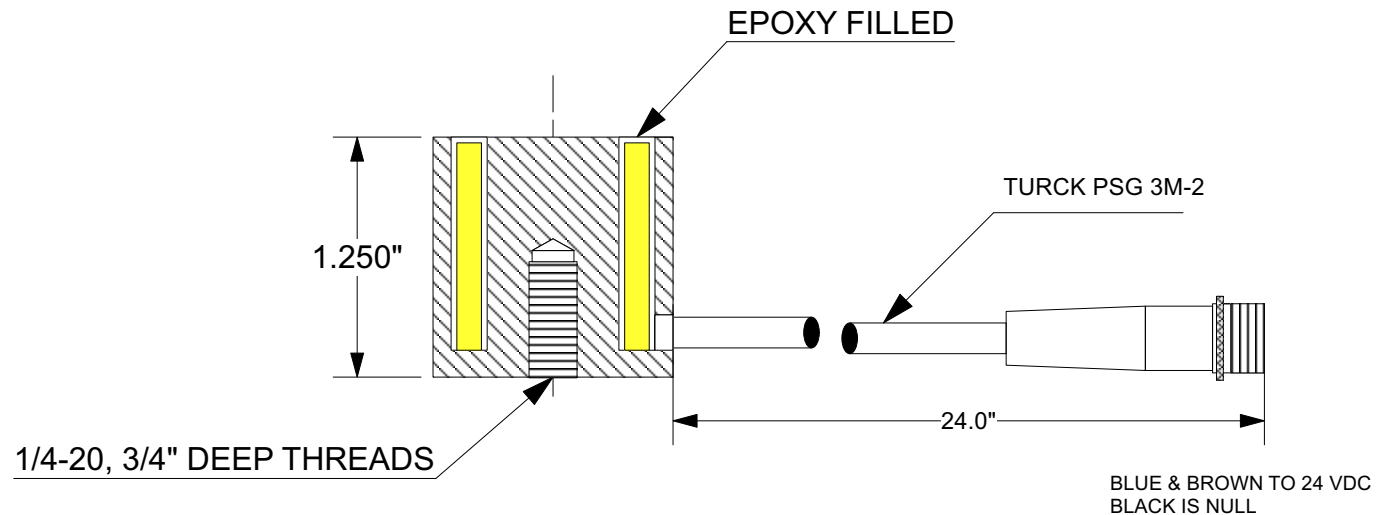
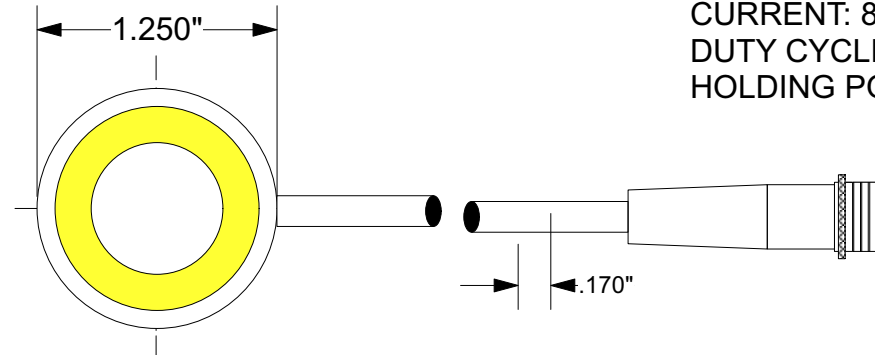

IF YOU HAVE ANY QUESTIONS ABOUT THIS MAGNET OR THE CORRESPONDING DC POWER SUPPLY, PLEASE CALL OUR ENGINEERING DEPARTMENT FOR ASSISTANCE: (1-800-635-3954)

AUTOMATIC EQUIPMENT CORP.
DC-125T-24C
CUST DWG
01/20/22
H-15455