

INSTALLATION:

THE E-STYLE DISCONNECT MATES WITH ANY OF OUR E-STYLE CORDS. APPLY 24 VDC TO THE BROWN AND BLUE LEADS, AND BLACK IS GROUND.

MAINTENANCE INSTRUCTIONS:

ELECTROMAGNETS REQUIRE VERY LITTLE MAINTENANCE TO PROVIDE A LONG USEFUL LIFE. DAILY USE OF A SHOP TOWEL TO WIPE THE FACE OF THE MAGNET FREE OF DEBRIS, GREASE AND OIL OR OTHER FOREIGN MATTER WILL ENSURE YEARS OF SERVICE LIFE AND THOUSANDS OF SAFE LIFTS.

BROWN & BLUE 24 VDC
BLACK GROUND
WHITE NULL

E STYLE
QUICK DISCONNECT



MAGNETICS

AUTOMATIC EQUIPMENT CORPORATION
4699 INTERSTATE DR, CINCINNATI, OHIO 45246

PHONE: (800) 635-3954 FAX: (800) 635-3955

E-MAIL: aec@aecmagnetics.com ON-LINE: www.aecmagnetics.com

MAGNETIC SPECIALISTS FOR AUTOMATED MANUFACTURING

MODEL: DCA-300E-24C

VOLTAGE: 24 VDC

POWER: 20 WATTS

DUTY CYCLE: CONTINUOUS

HOLDING POWER: 440 LBS

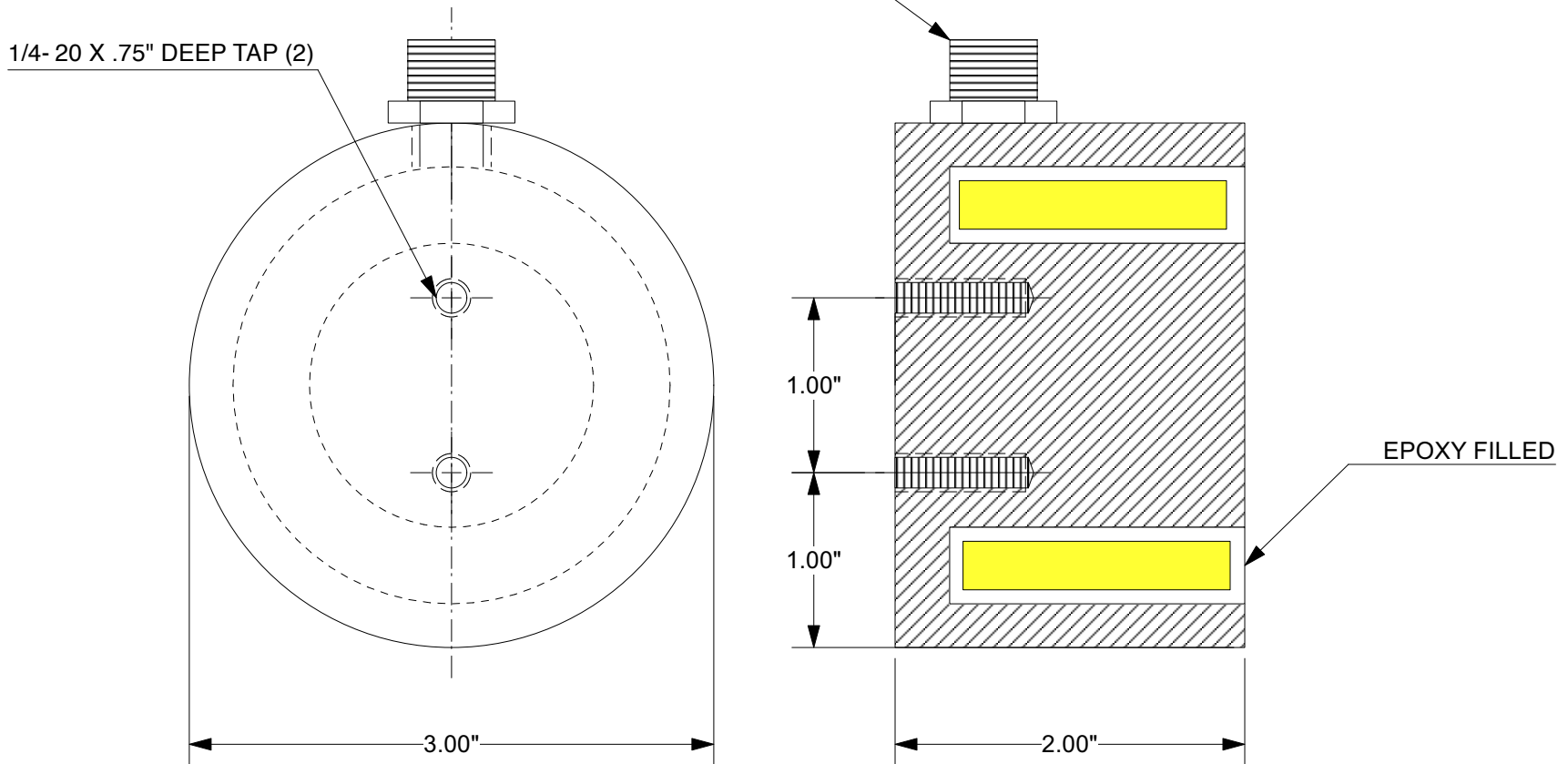

IF YOU HAVE ANY QUESTIONS ABOUT THIS MAGNET OR THE CORRESPONDING DC POWER SUPPLY, PLEASE CALL OUR ENGINEERING DEPARTMENT FOR ASSISTANCE: (1-800-635-3954)

AUTOMATIC EQUIPMENT CORP
DCA-300E-110C
CUST DWG
01/06/22
H-15436