

**INSTALLATION:**

Use threaded holes in the back of electromagnet to mount.

Apply 24 Volts DC to leads. Polarity is unimportant as electromagnets work equally well in forward or reverse polarity.

**MAINTENANCE INSTRUCTIONS:**

Electromagnets require very little maintenance to provide a long useful life. Daily use of a shop towel to wipe the face of the magnet free of debris, grease and oil or other foreign matter will ensure years of service life and thousands of safe lifts.

MODEL: DCS-500E-24C  
 VOLTAGE: 24VDC  
 POWER: 39 WATTS  
 DUTY CYCLE: CONTINUOUS  
 HOLDING POWER: 1400 LBS

BROWN & BLUE 24 VDC  
 BLACK GROUND  
 WHITE NULL

E STYLE  
 QUICK DISCONNECT

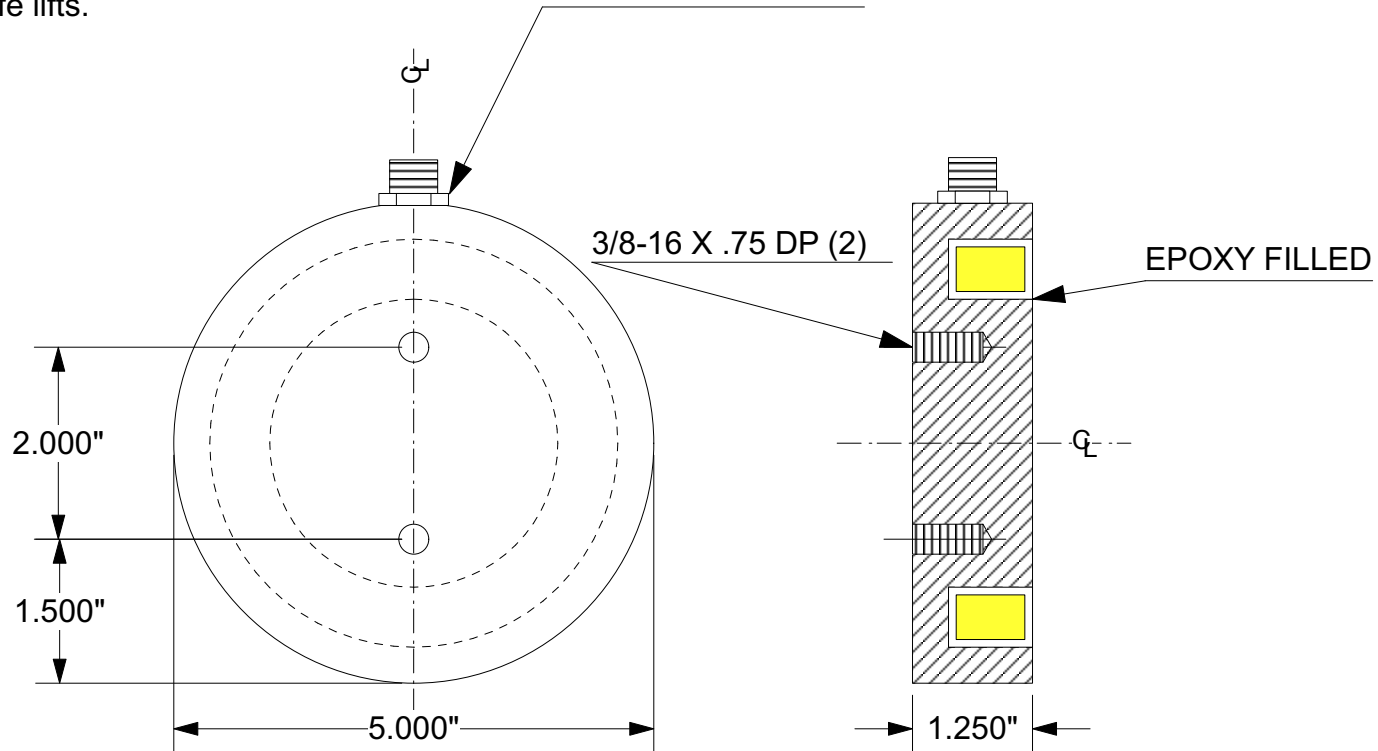

IF YOU HAVE ANY QUESTIONS ABOUT THIS MAGNET OR THE CORRESPONDING DC POWER SUPPLY, PLEASE CALL OUR ENGINEERING DEPARTMENT FOR ASSISTANCE: (1-800-635-3954)

AUTOMATIC EQUIPMENT CORP.  
 DCS-500E-24C  
 CUST DWG  
 01/06/22  
 H-15447